



ACVATIX™

Electromotoric actuators**SQL321B..****SQL361B..**

For VKF42..., VFF41... butterfly valves

-
- SQL321B.. Operating voltage AC 220 V, 2-position (SPDT) control signal
 - SQL361B.. Operating voltage AC 220 V, DC 0(2)...10 V, 4...20 mA control signal
 - Optional auxiliary switch for SQL361B150...B6000
 - Nominal angle of rotation 90°
 - Manual operating devices and position indicator
 - Built-in heating element to avoid condensation
 - Compatible with EN ISO 5211 flanges

Use

For operation of VKF42.., VFF41.. butterfly valves as shutoff and control valves in heating, ventilation and air conditioning plants.

Type summary

Product No.	Stock No.	Operating Voltage	Positioning Signal	Position Feedback Signal	Positioning Time for 90° at 50 Hz [s]	Nominal Torque [Nm]	Flange Connection EN ISO 5211
SQL321B25/1	S55164-A176	AC 220 V 1 phase	2-position (SPDT)	Dual auxiliary switch	18	25	F07
SQL321B50/1	S55164-A177		2-position (SPDT)	Dual auxiliary switch	30	50	F07
SQL321B150	S55164-A103		2-position (SPDT)	Dual auxiliary switch	39	150	F07
SQL321B270	S55164-A105		2-position (SPDT)	Dual auxiliary switch	39	270	F10
SQL321B570	S55164-A107		2-position (SPDT)	Dual auxiliary switch	47	570	F12/F10
SQL321B1400	S55164-A109		2-position (SPDT)	Dual auxiliary switch	47	1400	F14
SQL321B2650	S55164-A111		2-position (SPDT)	Dual auxiliary switch	105	2650	F16
SQL321B6000	S55164-A125		2-position (SPDT)	Dual auxiliary switch	143	6000	F25
SQL361B25	S55164-A113		DC 0(2)...10 V, 4...20 mA	DC 0 (2)...10 V, 4...20 mA, dual auxiliary switch	11	25	F07
SQL361B50	S55164-A102		DC 0(2)...10 V, 4...20 mA	DC 0 (2)...10 V, 4...20 mA, dual auxiliary switch	22	50	F07
SQL361B150	S55164-A104		DC 0(2)...10 V, 4...20 mA	DC 0 (2)...10 V, 4...20 mA	39	150	F07
SQL361B270	S55164-A106		DC 0(2)...10 V, 4...20 mA	DC 0 (2)...10 V, 4...20 mA	39	270	F10
SQL361B570	S55164-A108		DC 0(2)...10 V, 4...20 mA	DC 0 (2)...10 V, 4...20 mA	47	570	F12/F10
SQL361B1400	S55164-A110		DC 0(2)...10 V, 4...20 mA	DC 0 (2)...10 V, 4...20 mA	47	1400	F14
SQL361B2650	S55164-A112		DC 0(2)...10 V, 4...20 mA	DC 0 (2)...10 V, 4...20 mA	105	2650	F16
SQL361B6000	S55164-A126		DC 0(2)...10 V, 4...20 mA	DC 0 (2)...10 V, 4...20 mA	143	6000	F25

Ordering

The actuator, butterfly valve and any accessories must be ordered separately.

When ordering, specify the quantity, product name and product number.

Example

Product No.	Stock No.	Description	Quantity
SQL361B150	S55164-A104	Electromotoric actuator	1
ASC10.21	S55845-Z122	Double auxiliary switch	1

Delivery

The actuator, accessory and butterfly valve are packed separately and delivered as individual items.

Rev. No.

See chapter "Rev. No." on page 13.

Equipment combinations

Butterfly Valve	Electromotoric Actuators ¹⁾						
	SQL321B25/1 SQL361B25	SQL321B50/1 SQL361B50	SQL321B150 SQL361B150	SQL321B270 SQL361B270	SQL321B570 SQL361B570	SQL321B1400 SQL361B1400	SQL321B2650 SQL361B2650
	Δp_s [kPa]						
VKF42.50	700						
VKF42.65	700						
VKF42.80	700						
VKF42.100		700					
VKF42.125		700					
VKF42.150		700					
VKF42.200			700				
VKF42.250				700			
VKF42.300				700			
VKF42.350					700		
VKF42.400					700		
VKF42.450						700	
VKF42.500						700	
VKF42.600							700

Butterfly Valve	Electromotoric Actuators ¹⁾							
	SQL321B25/1 SQL361B25	SQL321B50/1 SQL361B50	SQL321B150 SQL361B150	SQL321B270 SQL361B270	SQL321B570 SQL361B570	SQL321B1400 SQL361B1400	SQL321B2650 SQL361B2650	SQL321B6000 SQL361B6000
	Δp_s [kPa]							
VFF41.40	1000							
VFF41.50	1000							
VFF41.65	1000							
VFF41.80	1000							
VFF41.100		1000						
VFF41.125		1000						
VFF41.150		1000						
VFF41.200			1000					
VFF41.250				1000				
VFF41.300				1000				
VFF41.350					1000			
VFF41.400					1000			
VFF41.450						1000		
VFF41.500						1000		
VFF41.600							1000	
VFF41.700							1000	
VFF41.800								1000
VFF41.900								1000

¹⁾ SQL321B..., SQL361B.. electromotoric actuators can be mounted directly on VKF42.. or VFF41.. butterfly valves.

Δp_s Maximum permissible differential pressure at which the motorized butterfly valve will close securely against the pressure (close off pressure)

The actuator is driven by a 2-position (SPDT) or DC 0(2)...10 V, 4...20 mA control signal from the controller and generates a rotary motion which is transferred to the butterfly valve via a driver.

These electromotoric actuators require no maintenance. They have a reversible asynchronous motor which drives the main shaft via gear train, which accommodates the diagonal square head of the butterfly valve. SQL321B25/1, SQL321B50/1 use an 8mm wrench on the bottom of the actuator for manual operation. For SQL361B25/B50, the handwheel shaft is spring-mounted, so the handwheel must be kept pushed in for manual operation. For other product types, the handwheel is attached directly to the worm shaft fitted with a direct-acting operation.

The actuators are 90° rotated so as to work with Siemens VKF42.., VFF41.. butterfly valves. During automatic operation, rotation is stopped by two built-in end-switches.

To prevent the temperature inside the housing from falling below the dew point temperature, the actuators are equipped with a built-in heating element.

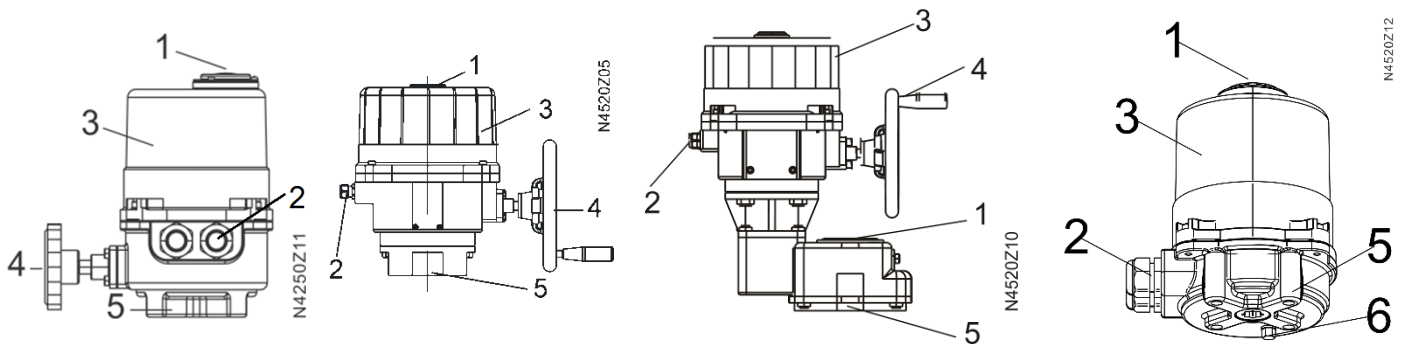







- | | |
|------------------------|---------------------------------|
| 1 Position indication | 4 Handwheel |
| 2 Terminal compartment | 5 EN ISO 5211 flange connection |
| 3 Cover (motor inside) | 6 Manual operating devices |

**Calibration
SQL361B..**

In order to determine the disc position fully closed “0 %” or fully open “100 %”, calibration is recommended on initial commissioning of modulating type actuator.

SQL361B25..B50

Prerequisites		
<ul style="list-style-type: none"> • Actuator is mounted on butterfly valve • Rotate the actuator to the half-open position using the handwheel • Housing cover is removed 		
Calibration	LED on PCB	Actuator Movement
1. Supply power to terminal 1 and 2.	 Flash	Actuator moves to the position as indicated by control signal. (D4 flash)
2. Press button S1 for 3 seconds	 Lit	Actuator moves to “100 %” position (valve open). (D4 light)
	 Flash once	Actuator stops at “100 %” position (valve open), indicate light flashes (D6), and then the actuator is ready to move towards “0 %” position (valve closed).
	 Flash once	Actuator moves to “0 %” position (valve closed). (D7 flash once)
	 Flash	Actuator stops at “0 %” position (valve closed). The indicate light flashes (D4), and then the calibration finished.
3. Calibration finished.	 Flash	Actuator moves to the position as indicated by control signal. (D4 flash)

W1, 20 mA calibration potentiometer
/ 20 mA 校准电位计

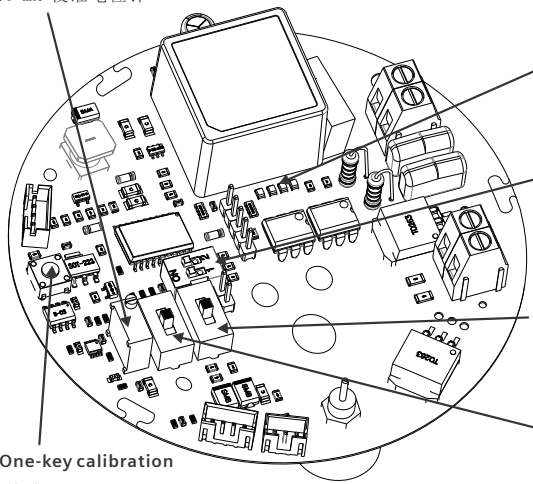

From left to right are D4/D10/D7/D6
/ 从左到右为 D4/D10/D7/D6

S4, Signal loss mode settings.
/ 信号丢失模式设置

S2, Selection of Input Signal Types.
/ 选择输入信号类型

S3, Selection of Feedback Signal Types.
/ 选择反馈信号类型

S1, One-key calibration
/ 一键校准

Signal loss mode settings







State Position	Run to 0 % (default)	Hold position		Run to 100 %
DIP 1	OFF	ON	OFF	ON
DIP 2	OFF	OFF	ON	ON

Note:

-Control signal 0-10 V, when signal loss, the valve runs to 0 %.

-Control signal 2-10 V, when signal loss, the valve runs to 0 % or 100 % by adjusting DIP 1&2.

-Control signal 4-20 mA, when signal loss, the valve runs to 0 %, hold position or 100 % by adjusting DIP 1&2.

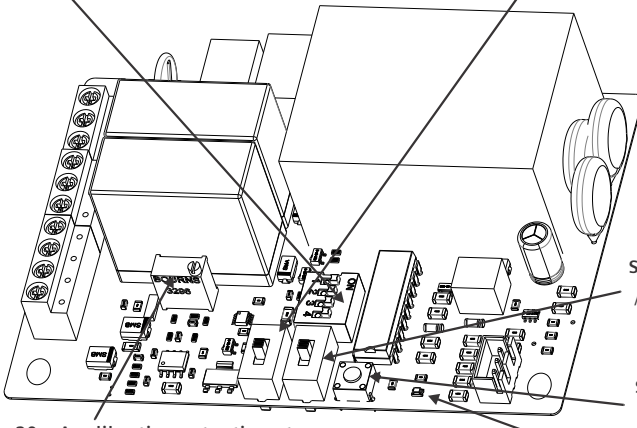
Prerequisites			
<ul style="list-style-type: none"> • Actuator is mounted on butterfly valve • Rotate the actuator to the half-open position using the handwheel • Housing cover is removed 			
Calibration	LED on PCB		Actuator Movement
1. Supply power to terminal 1 and 2.		Lit	Actuator moves to the position as indicated by control signal.
2. Press button S1 for 3 seconds		Dark	Actuator moves to "100 %" position (valve open).
		Flash once	Actuator stops at "100 %" position (valve open), indicate light flashes, and then the actuator is ready to move towards "0 %" position (valve closed).
		Dark	Actuator moves to "0 %" position (valve closed).
		Flash	Actuator stops at "0 %" position (valve closed). The indicate light flashes, and then the calibration finished.
3. Calibration finished.		Lit	Actuator moves to the position as indicated by control signal.
<p>S4, Signal loss mode settings / 信号丢失模式设置</p> <p>S3, Selection of Feedback Signal Types (0-10V 2-10V 4-20mA) / 选择反馈信号类型 (0-10V 2-10V 4-20mA)</p>  <p>S2, Selection of Input Signal Types. / 选择输入信号类型</p> <p>S1, One-key calibration / 一键校准</p> <p>W1, 20 mA calibration potentiometer / 20 mA 校准电位计</p> <p>LED D3</p>			

Signal loss mode settings

State Position	Run to 0 % (default)	Hold position		Run to 100 %
DIP 1	OFF	ON	OFF	ON
DIP 2	OFF	OFF	ON	ON
DIP 3	Reserve			
DIP 4	Reserve			











Note:

- Control signal 0-10 V, when signal loss, the valve runs to 0 %.
- Control signal 2-10 V, when signal loss, the valve runs to 0 % or 100 % by adjusting DIP 1&2.
- Control signal 4-20 mA, when signal loss, the valve runs to 0 %, hold position or 100 % by adjusting DIP 1&2.

Indication of operating state SQL361B..

SQL361B25..50

The LED display indicating operating status can be viewed by opening the cover of the electronics module.





Function	LED Indication		Remarks, troubleshooting
	D10	D4	
Calibration mode	OFF 	ON 	Run calibration, everything ok. ¹⁾
	ON 	Flashing 	Calibration error.
Control mode	OFF 	Flashing 	Automatic operation; everything o.k. ^{1), 2)}
	ON 	Flashing 	Internal error, troubleshooting
	OFF 	OFF 	No power Troubleshooting, eventually replace actuator

As a general rule, the LED can assume only the states shown above (continuously red, flashing, or off).

¹⁾ The Green LED (D6) with short lit on when reach to «100 %» and the Red LED (D7) with short lit on when reach to «0 %» stroke position.

²⁾ When power supply to actuator but no Y control signal and also calibration not started, LED will be continuously red too.

SQL361B150...6000

Function	LED Indication	Remarks, troubleshooting
Calibration	Off 	Run calibration, everything o.k.
	Flashing 	Calibration error
Control mode	Lit 	Automatic operation; everything o.k. ¹⁾
	Flashing 	Internal error, troubleshooting
	Off 	No power Troubleshooting, eventually replace actuator







As a general rule, the LED can assume only the states shown above (continuously red, flashing, or off).

¹⁾ When power supply to actuator but no Y control signal and also calibration not started, LED will be continuously red too.

0..10 V and 4..20 mA signal SQL361B..

SQL361B25..50

- Factory setting for input and output signal in SQL361B.. is 0..10 V.
- Select switch as below description.

Signal	Input	Output
	S3	S2
0-10 V		
2-10 V		
4-20 mA		

- Factory setting for input and output signal in SQL361B.. is 0...10 V.
- Select switch as below description.

Signal	Input	Output
	S3	S2
0-10 V		
2-10 V		
4-20 mA		

Accessories

Product No.	Stock No.	Figure	Description	For Actuators
ASC10.21	S55845-Z122		Double auxiliary switch	SQL361B150 SQL361B270 SQL361B570 SQL361B1400 SQL361B2650 SQL361B6000

Engineering notes

Electrical installation

The actuators must be electrically connected in accordance with local regulations and with the connection diagrams.

Warning



Regulations and requirements to ensure the safety of people and property must be always observed.

Mounting notes

Mounting instructions

Product No.	Documentation No.
VKF42..	74 319 0808 0 (M4119)
VFF41..	A5W00119634A (A6V12045430)
SQL321B.. / SQL361B..	74 319 0809 0 (M4520)
ASC10..	74 319 0810 0 (M4520.1)

These actuators can be mounted directly on type VKF42.., VFF41.. butterfly valves. The butterfly valves have to be closed "0 %" when the actuators are mounted onto the valves.

Orientation

The valve and actuator can be assembled on site. There is no need for special tools.

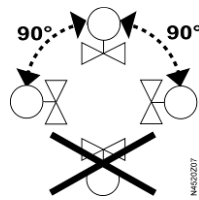

Upright to horizontal

Commissioning notes

When commissioning the motorized butterfly valves, always check wiring and test the functions. This also applies to any additional components fitted, e.g. auxiliary switch.

Warning



To avoid pressure shocks on the butterfly valve, the VKF42.., VFF41.. must be driven to its fully open position either manually or via positioning signal prior to activating the pump(s).

The flow rate can be adjusted either by operating the electric actuators when necessary, or by operating the handwheel.

Operating notes

Manual operation mode

SQL321B25...B50/1	Manual operation with 8 mm wrench
SQL361B25...B50	Handwheel is engaged by pushing the handwheel in.
SQL321B150...B6000 SQL361B150...B6000	The handwheel is always engaged.

Reversing the direction of rotation

If the direction of rotation needs to be reversed, simply exchange the connections Y12 and Y14.

Setting the angle of rotation

The 0...90° angle of rotation for the mechanical limit switches is factory-set and cannot be changed. The SQL321B25/1 and SQL321B50/1 has no mechanical limits.

The potential-free auxiliary switches are equipped with adjustable switching points.

Duty cycle value

SQL..B25...570: 50%; SQL..B1400...2650: 30%; SQL..B6000: 15%.
Note that the time of actuator motor starts per hour should not exceed 630.

Maintenance notes

The actuators and butterfly valves require no maintenance.

Warning



Before performing any service work on the valve or actuator:

- Switch off the pump and power supply
- Close the main shut-off valves in the pipe work
- Release pressure in the pipes and allow them to cool down completely

If necessary, disconnect electrical connections from terminals.

The valve must be re-commissioned only with the handwheel or the actuator correctly assembled.

Disposal



The device is considered electrical and electronic equipment for disposal in terms of the applicable European Directive and may not be disposed of as domestic garbage.

- Dispose of the device through channels provided for this purpose.
- Comply with all local and currently applicable laws and regulations.

Warranty

The engineering data specified in chapter "Equipment combinations" (page 3) are only guaranteed in connection with the Siemens butterfly valves listed.

Note When using the actuators in connection with butterfly valves of other manufacture, correct functioning must be ensured by the user, and Siemens will assume no responsibility.

Technical data

		SQL321B25/1	SQL321B50/1	SQL321B150	SQL321B270	SQL321B570	SQL321B1400	SQL321B2650	SQL321B6000	
		SQL361B25	SQL361B50	SQL361B150	SQL361B270	SQL361B570	SQL361B1400	SQL361B2650	SQL361B6000	
Power supply	Operating voltage	AC 220 V / 1 phase								
	Voltage tolerance	+/- 10%								
	Frequency	50 / 60 Hz								
	Power consumption ¹⁾	45 VA	45 VA	91 VA	165 VA	194 VA	390 VA	436 VA	670 VA	
Signal inputs	Positioning signal	SQL321...: 2P (SPDT) SQL361...: DC 0(2)...10 V / 4...20 mA								
	Parallel operation	For SQL321B.., it is not possible for electrical parallel operation of several actuators. For SQL361B.. electrical parallel operation of several actuators is possible, and the specific quantity of actuator depends on the controller output.								
	Position feedback	SQL321B.. Dual auxiliary switch (built-in) SQL361B25..B50 DC 0(2)...10 V / 4...20 mA , Dual auxiliary switch (built-in) SQL361B150..., B6000 DC 0(2)...10 V / 4...20 mA								
Operating data	Positioning time for 90° at 50 Hz	18/11 s	30/22 s	39 s	39 s	47 s	47 s	105 s	143 s	
	Angle of rotation	90° ± 1° (factory setting)								
	Nominal Torque ¹⁾	25 Nm	50 Nm	150 Nm	270 Nm	570 Nm	1400 Nm	2650 Nm	6000 Nm	
	Switching capacity	AC 250 V, 5 A resistive		AC 250 V, 10 A resistive						
	Heating element (built-in)	220 V 2.0 W		220 V 7.5 W	220 V 8.5 W					
	Max. permissible medium temperature	-10...80 °C								
Degree of protection	Housing upright to horizontal	IP67 as per EN 60529								
	Insulation class	Class I as per EN 60730								
Standards	EU conformity (CE)	A5W90000890*								
	RCM conformity	A5W90000886*								
Environmental compatibility	The product environmental declaration A5W02116952A*(SQL321/361B25...50), A5W02627389A*(SQL321/361B150...6000) contains data on environmentally compatible product design and assessments (RoHS compliance, materials composition, packaging, environmental benefit, disposal).									
	Flange / shaft connection types to valve (top flange)	EN ISO 5211		F07	F10	F12/F10	F14	F16	F25	
Dimension weight	Dimensions	see "Dimensions", page 11, 12								
	Weight	see "Dimensions", page 11, 12								
	Cable glands	2 x Pg 13.5				2 x Pg 16				
Materials	Housing base, yoke	Die-cast aluminum alloy						Housing: Die-cast aluminum alloy Gear box: Cast Iron		
	Cover	SQL321B25/1, SQL321B50/1: ABS SQL361B25/B50, SQL321/361B150...B6000: Die-cast aluminum alloy								

¹⁾ These values apply at nominal voltage, ambient temperature of 20 °C and at nominal running time.

* The documents can be downloaded from <http://siemens.com/bt/download>.

General ambient conditions

	Operation	Transport	Storage
Temperature	-20...65 °C	-30...65 °C	-5...55 °C
Humidity	15...100 % r. h.	< 95 % r. h.	0...95 % r. h.

Internal diagrams

SQL321..

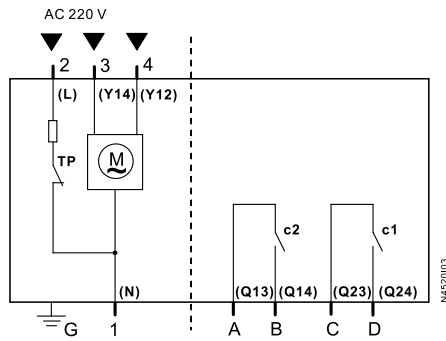

Pin	Terminal no.	Code	Meaning
Actuator AC 220 V	G	-	Grounding
	1	N	System neutral
	2	L	System potential, AC 220 V
	3	Y14	AC 220 V, control signal (open)
	4	Y12	AC 220 V, control signal (closed)
Auxiliary signal feedback	A	Q13	Auxiliary switch c2, open
	B	Q14	Auxiliary switch c2, open
	C	Q23	Auxiliary switch c1, close
	D	Q24	Auxiliary switch c1, close

SQL361B25 SQL361B50

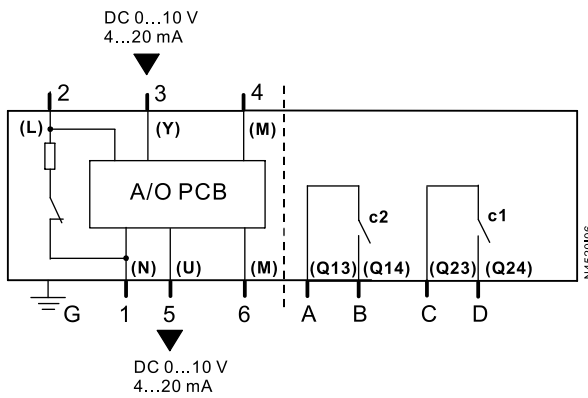

SQL361B150... B6000

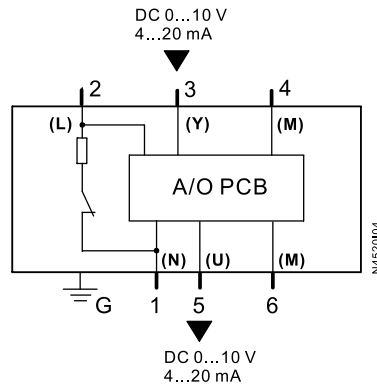

Accessory ASC10.21

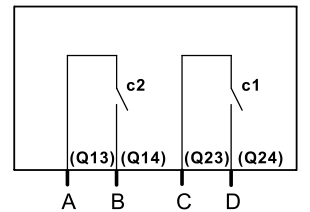

Pin	Terminal no.	Code	Meaning
Actuator AC 220 V	G	-	Protective earth
	1	N	Neutral
	2	L	System potential, AC 220 V
	3	Y	Positioning signal, DC 0(2)...10 V, 4...20 mA
	4, 6	M	Measuring neutral
	5	U	Position feedback, DC 0(2)...10 V, 4...20 mA
Auxiliary signal feedback	A	Q13	Auxiliary switch c2, open
	B	Q14	Auxiliary switch c2, open
	C	Q23	Auxiliary switch c1, close
	D	Q24	Auxiliary switch c1, close

Connection diagrams

SQL321B..

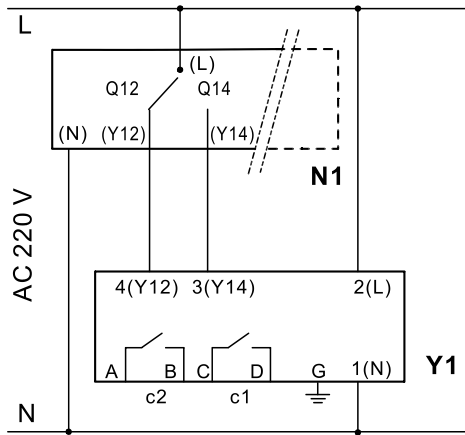

- N1 Controller
- Y1 Actuator
- L 1 phase AC 220 V
- N Neutral
- Q12, Q14 Controller contacts
- Y12 Positioning signal (Closed)
- Y14 Positioning signal (Open)
- c1 Auxiliary dry contact switch, close
- c2 Auxiliary dry contact switch, open

N4520V01

SQL361B..

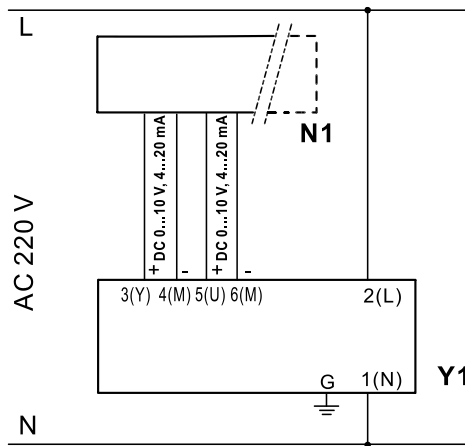

- N1 Controller
- Y1 Actuator
- L 1 phase AC 220 V
- N Neutral
- Y Positioning signal DC 0(2)...10 V, 4...20 mA
- M Measuring neutral
- U Position feedback signal DC 0(2)...10 V, 4...20 mA

N4520V02

Dimensions (mm)

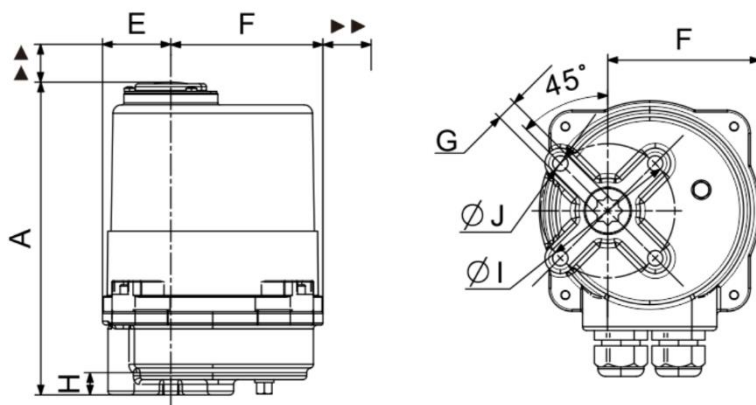

Product No.	A	E	F	H	G	Ø I	J	Weight [kg]	EN ISO 5211
SQL321B25/1	164	36	79	20	11	70	4-M8	1.9	F07
SQL321B50/1	174	36	79	20	17	70	4-M8	2.1	F07
▲ ▲	▶ ▶	≥ 200 mm: For mounting, connection, operation, service, etc.							

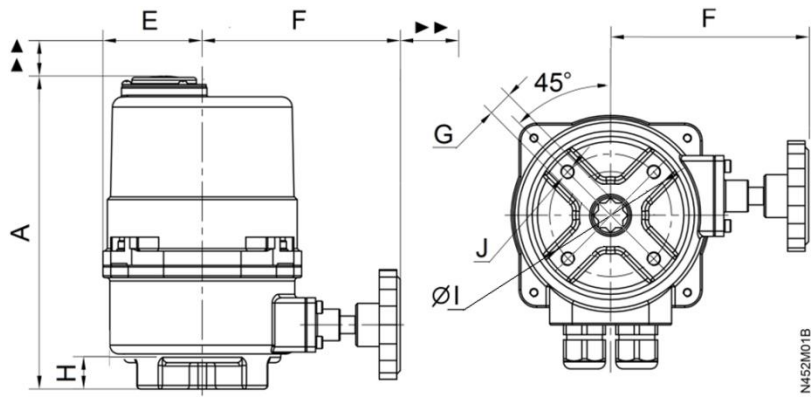

Product No.	A	E	F	H	G	Ø I	J	Weight [kg]	EN ISO 5211
SQL361B25	199	57	114	20	11	70	4-M8	3.8	F07
SQL361B50	199	57	114	20	17	70	4-M8	3.8	F07
▲ ▲	▶▶	≥ 200 mm: For mounting, connection, operation, service, etc.							

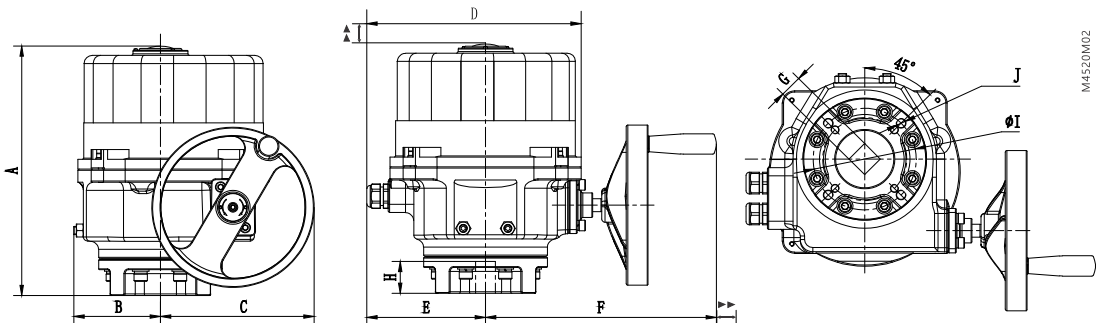

Product No.	A	B	C	D	E	F	G	H	Ø I	J	Weight [kg]	EN ISO 5211
SQL321B150 SQL361B150	248	79	123	218	123	243	17	35	70	4-M8	11	F07
SQL321B270 SQL361B270	307	109	187	262	146	280	22	55	102	4-M10	22	F10
SQL321B570 SQL361B570	307	109	187	262	146	280	27	55	102 125	4-M10 4-M12	22	F10/F12
SQL321B1400 SQL361B1400	359	128	242	295	163	333	36	65	140	4-M16	35	F14
▲ ▲	▶▶	≥ 200 mm: For mounting, connection, operation, service, etc.										

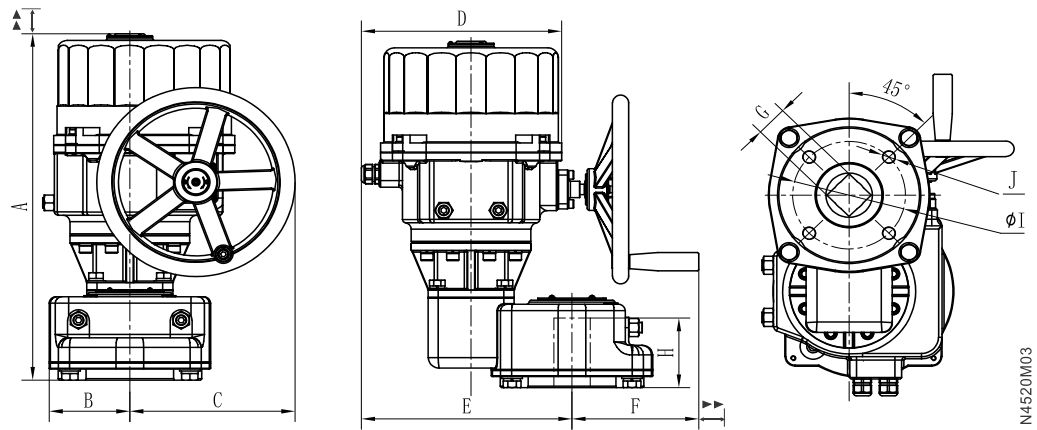

Product No.	A	B	C	D	E	F	G	H	Ø I	J	Weight [kg]	EN ISO 5211
SQL321B2650 SQL361B2650	532	118	242	293	308	186	46	130	165	4-M20	76	F16
▲ ▲	▶ ▶	≥ 200 mm: For mounting, connection, operation, service, etc.										

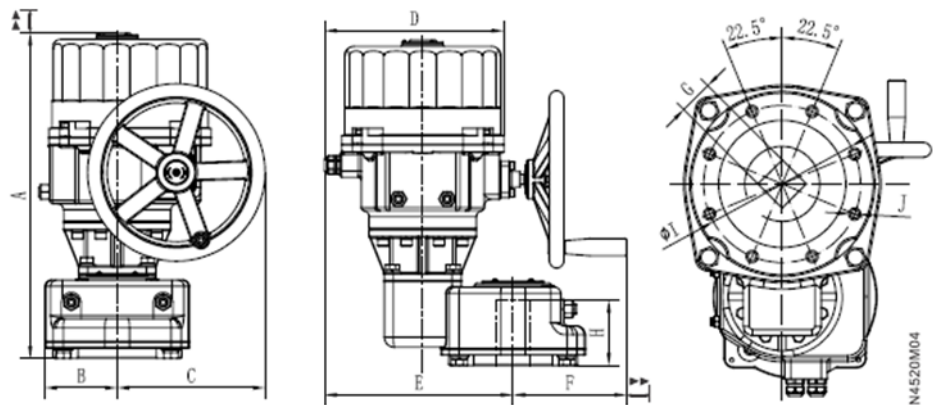

Product No.	A	B	C	D	E	F	G	H	Ø I	J	Weight [kg]	EN ISO 5211
SQL321B6000 SQL361B6000	545	160	242	293	343	160	60	150	254	8-M16	107	F25
▲ ▲	▶ ▶	≥ 200 mm: For mounting, connection, operation, service, etc.										

Revision numbers

Product No.	Valid from Rev. No.	Product No.	Valid from Rev. No.
SQL321B25/1	..A	SQL361B25	..A
SQL321B50/1	..A	SQL361B50	..E
SQL321B150	..D	SQL361B150	..D
SQL321B270	..D	SQL361B270	..D
SQL321B570	..D	SQL361B570	..D
SQL321B1400	..D	SQL361B1400	..D
SQL321B2650	..D	SQL361B2650	..D
SQL321B6000	..A	SQL361B6000	..A

Issued by
Siemens Switzerland Ltd.
Smart Infrastructure
International Headquarters
Gubelstrasse 22
CH-6300 Zug
Tel. +41 58-724 24 24
www.siemens.com/buildingtechnologies

© Siemens, 2011 - 2024
Technical specifications and availability subject to change without notice.