



TX-I/O™

## Island bus expansion module

**TXA1.IBE**

- 
- Expand island bus to a distance of up to 2 x 200 meters
  - Compact design per DIN 43 880, requires little space
  - Easy installation and setup
    - Mounted on standard rails
    - Self-connecting bus (island bus) for the easiest possible installation
    - Plug-in screw terminals for island bus expansion
    - No programming / parameterization tool required

## Function

---

- The island bus expansion modules allow for “decentralized” sub-islands with TX-I/O-modules, that may be located up to 2 x 200 m from the "local" sub-island.
- A programming / parameterization tool is not required.
- The DIP switches for the bus master and bus terminator must be set correctly on the island bus expansion modules.
- The island bus expansion is based on differential RS-485 transmission technology.
- "Decentralized" sub-island can be supplied using a separate power supply. Loss of this power does not impact the island bus of local sub-islands.

For details on wiring and topology, refer to TX-I/O™ engineering and installation manual, CM110562.

## Type summary

---

Island bus expansion module **TXA1.IBE**

## Ordering

---

When ordering, please specify the quantity, product name, and type code.

*Example:*

10      Island bus expansion modules      **TXA1.IBE**

## Equipment combinations

---

### Compatibility

- Full functionality is only possible using
- TX-I/O modules from series C and higher
  - P-bus interface modules series B and higher
  - PXC-NRUD Series C and higher only (Migration – INTEGRAL AS1000)
  - All models of PROFINET BIM

Functionality is reduced when using modules for series B and BIM series A: refer to CM110562.

### System restrictions

Number of decentralized sub-islands per I/O island	Max. 8
Number of island bus expansion modules per decentralized sub-island	Exactly 1
Number of I/O modules per I/O island	Maximum of 64
Number of I/O modules per sub-island	No limit, as long as the total of the entire island (64) is maintained.

Island bus and island bus expansion are designed for indoor use in one building only.

See TX-I/O engineering and installation manual, CM110562 for more details.

Overview

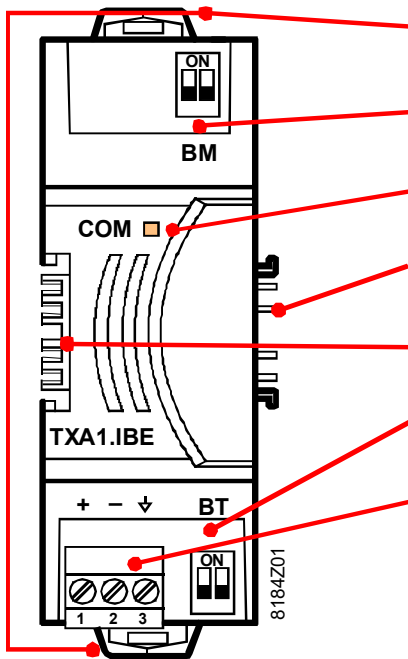

- Attachment slider for standard rails
- BM DIP switch \*) for bus master (island bus)
- LED "COM", displays island bus communication
- Bus connector right
- Bus connector left
- BT DIP switch \*) for bus terminal (island bus expansion)
- Plug-in screw terminals
  - + Signal island bus expansion
  - Signal island bus expansion
  - ⚡ equipotential bonding

\*) DIP switch:

Both "BM" switches must have the same position.  
The same applies to "BT" switches.

For details on wiring and topology, refer to TX-I/O™ engineering and installation manual, CM110562.

Mechanical properties

- The housing complies with DIN 43880 and is 32mm wide.
- The island bus expansion module is plugged on the right side of the power module / bus connection module on the standard rail. The electrical connection is on the 4 side island bus contacts. The bus establishes its own connection, when TX-I/O™ devices are plugged into one another on the rails.

Electrical properties

Interfaces

- **Island bus expansion:** Plug-in screw terminals
- **Island bus:** Bus connector on the right and left side of the module.

System ground

- Island bus and island bus expansion are galvanically connected

Protection against incorrect wiring

- All terminals are protected against short circuit and incorrect wiring using AC/DC 24 V.
- This applies as well to reverse phase voltage AC 24 V
- **Side bus connector: No protection**



Signaling

LED "COM" (yellow)

The LED indicates bus traffic on the island bus:

- Both directions OK: irregular blinking
- Bus short circuit: bright ON

## Schematic

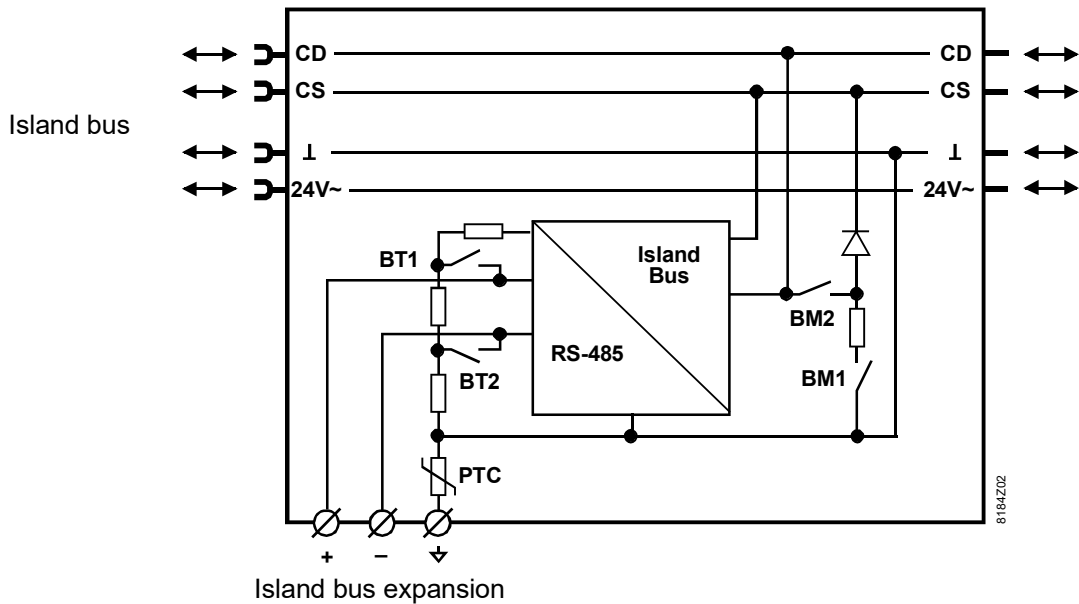

## Engineering, topology

- Please consult the following document:  
TX-I/O™ engineering and installation manual, CM110562.
- Island bus and island bus expansion are designed for indoor use only

## Mounting

### Fixings

The device is mounted on a standard rail 35 x 7.5 mm (tophat rails TH35-7.5 per EN60715)

### Mounting order

An island bus expansion module can be placed anywhere in the I/O row. For signal quality reasons, however, the best place is directly after the supplying device (automations station, power supply module, bus connection module or bus interface module).

See also the connection examples on pages 7 and 8.

### Exchange

An island bus expansion module may be removed from the row. **The electronic component from the neighboring right module must, however, be removed.** Its terminal block may remain.

### Permissible mounting positions

TX-I/O™ devices can be mounted in any position: horizontally, vertically, on a horizontal surface.

You must ensure, however, that sufficient ventilation is available to maintain the permissible ambient temperature (max. 50°C).

## Disposal



The devices are considered electronics devices for disposal in terms of European Directive 2012/19/EU and may not be disposed of as domestic garbage.

- Dispose of the devices through channels provided for this purpose.
- Comply with all local and currently applicable laws and regulations.

## Technical data

Supply (bus connector on side)	Operating voltage range	DC 21.5...26 V (SELV / PELV) or DC 24 V class 2 (US)
	Max. power consumption <i>(for the sizing of power supplies, see CM110562)</i>	1.2W
Maximum distances <i>(only with TX-I/O modules series C and higher; only with BIM Series B and higher)</i>	Island bus expansion	Max. 2 x 200 m
	Island bus inside of a sub-island (depending on cross section and current load – for details, refer to TX-I/O™ engineering and installation manual, CM110562)	Max. 50 m with round cable Max. 100 m with RG-62
Number of supported modules	Bus expansion modules per I/O island	Max. 9 modules
	I/O modules per I/O island	Max. 64 modules
Island bus communication	Island bus traffic display	LED "COM"
	Bus master function	2 DIP switches "BM" = ON
	Bus terminator function (terminator)	2 DIP switches "BT" = ON
Galvanic isolation	Island bus and island bus expansion are galvanically connected via PTC (Conductors $\perp$ and $\nabla$ ).	
Short-circuit protection and incorrect wiring	Side bus connector	No protection!
	Terminal	See below
Cabling	For details on cabling for RS485 and wiring rules, refer to TX-I/O™ engineering and installation manual, CM110562.	
Connection terminals, plug-in, for island bus expansion	Mechanical design	Plug-in screw terminal
	Copper wire	1 x 0.6 mm $\varnothing$ to 2.5mm <sup>2</sup> or 2 x 0.6 mm $\varnothing$ to 1.0 mm <sup>2</sup>
	Copper stranded wires with ferrules	1 x 0.6 mm $\varnothing$ to 2.5mm <sup>2</sup> or 2 x 0.6 mm $\varnothing$ to 1.0 mm <sup>2</sup>
	Copper stranded wires without ferrules	1 x 0.6 mm $\varnothing$ to 2.5 mm <sup>2</sup> or 2 x 0.6 mm $\varnothing$ to 1.5 mm <sup>2</sup>
	Screwdriver	Flat screwdriver size 1 with <i>shaft</i> $\varnothing \leq 4.5$ mm
	Maximum stud torque	0.6 Nm
Classification per EN 60730	Function of automatic control devices	Type 1
	Degree of pollution	
	Mechanical design	2 Protection class III
Housing type	IP class per EN 60529	
	Front parts in DIN excerpt	IP30
	terminal part	IP20

Ambient conditions	Operation		As per IEC 60721-3-3
	Climatic conditions		Class 3K5
	Temperature		-5 ... 50 °C
	Humidity		5 ... 95 % r.h.
	Mechanical conditions		Class 3M2
Standards, directives and approvals	Transport		As per IEC 60721-3-2
	Climatic conditions		Class 2K3
	Temperature		-25 ... 70 °C
	Humidity		5 ... 95 % r.h.
	Mechanical conditions		Class 2M2
Standards, directives and approvals	Product standard	EN 60730-1	Automatic electrical controls for household and similar use
	Electromagnetic compatibility (Applications)		For use in residential, commercial, light-industrial and industrial environments
	EU conformity (CE)		CM1T10870xx *)
	UL certification (US)		UL 916, UL 864, <a href="http://ul.com/database">http://ul.com/database</a>
	CSA certification		Class 3862 , Class 4812 <a href="https://www.csagroup.org/testing-certification/product-listing/">https://www.csagroup.org/testing-certification/product-listing/</a>
Environmental compatibility	RCM-conformity (EMC)		CM1T10870en_C1 *)
	EAC conformity		Eurasia conformity
	Product environmental declaration (contains data on RoHS compliance, materials composition, packaging, environmental benefit, disposal)		CM2E8184 *)
Color	Housing		Light gray, RAL 7035
Dimensions	Housing as per DIN 43880, see dimensions		
Weight	Without / with packaging		64 / 84 g

\*) The documents can be downloaded from <http://siemens.com/bt/download>.

See TX-I/O engineering and installation manual, CM110562 for more details.

A) Maximum 2 segments of max. 200 meters each are possible using the island bus expansion modules

A)

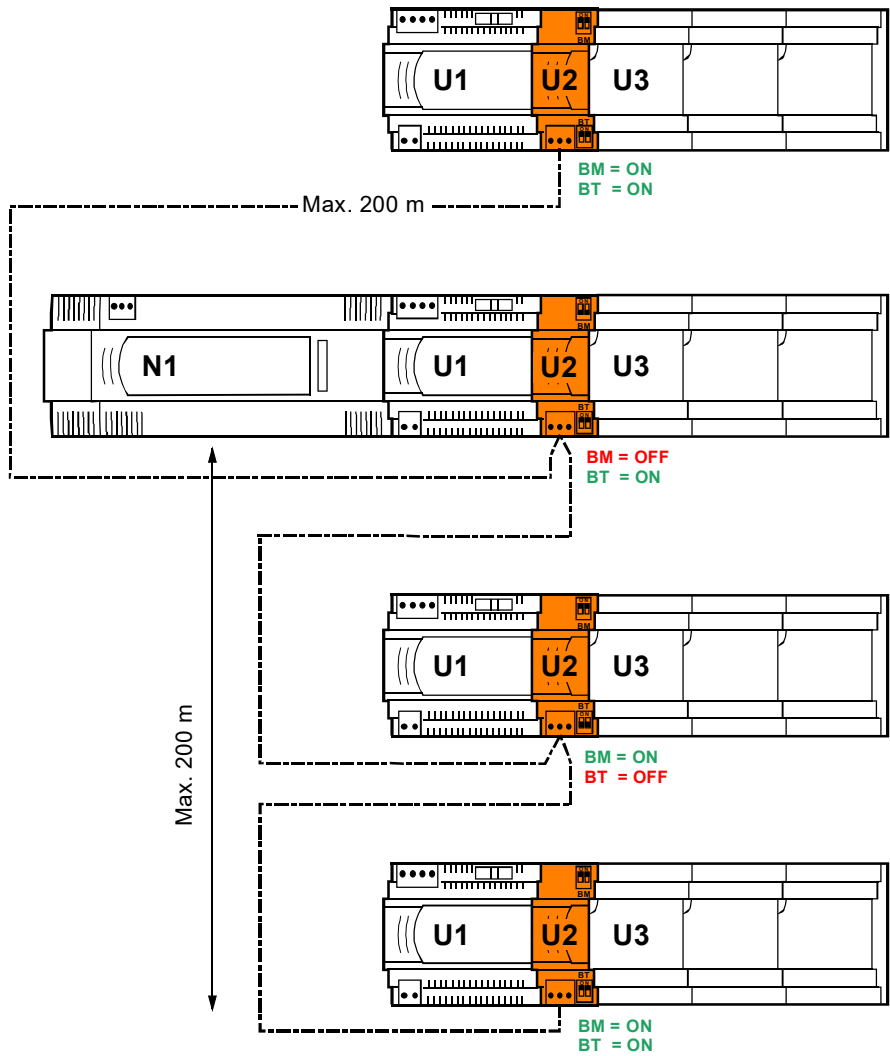

Key

- N1 Automation station with island bus or PROFINET BIM
- U1 Power supply module
- U2 Island bus expansion module
- U3 TX-I/O modules
- X1 Bus connection module
- BM Bus master function (island bus, both switches in the same position!)
- BT Bus terminator function (island bus expansion, both switches in the same position!)

B) Decentralized sub-island without power supply module (maximum distance depends on current on conductors CS and ⊥)

B)

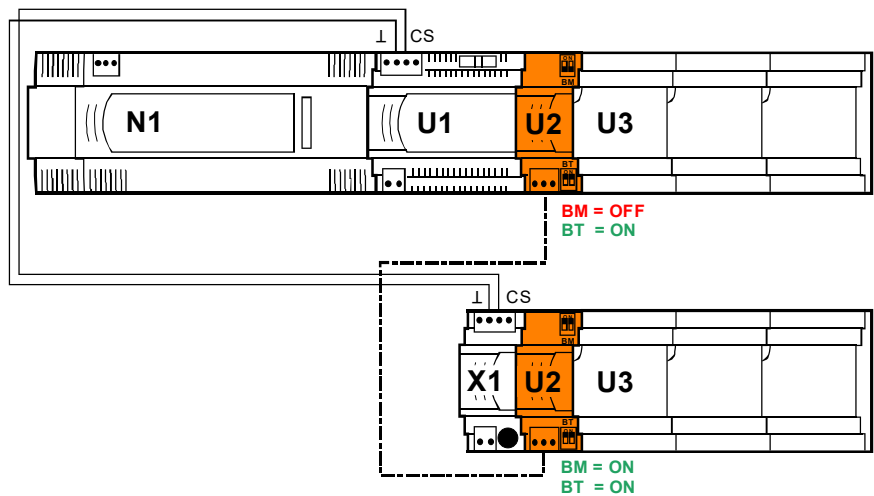

8184A01e

Connection examples for automation station with P-bus

See TX-I/O engineering and installation manual, CM110562 for more details.

C) Maximum 2 segments of max. 200 meters each are possible using the island bus expansion modules

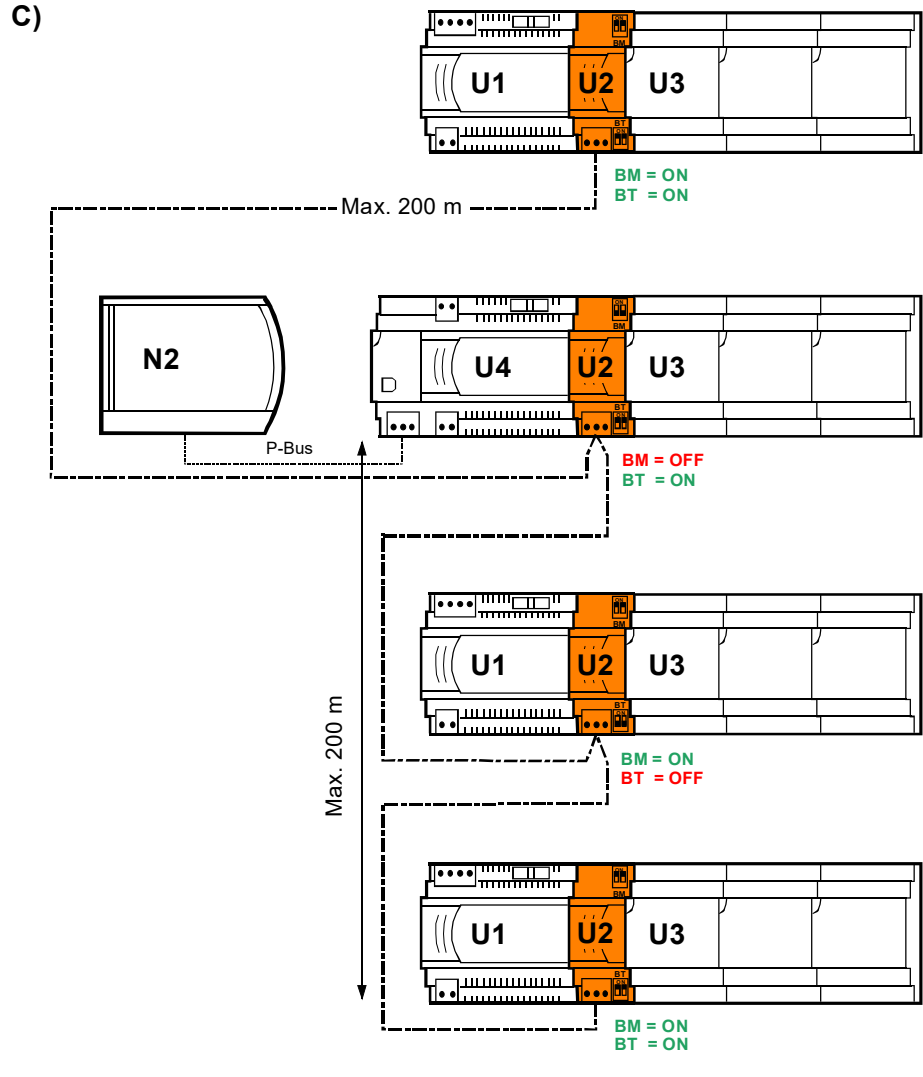

Key

- N2 Automation station with P-bus
- U1 Power supply module
- U2 Island bus expansion module
- U3 TX-I/O modules
- U4 P-bus interface module
- X1 Bus connection module
  
- BM Bus master function (island bus, both switches in the same position!)
- BT Bus terminator function (island bus expansion, both switches in the same position!)

D) Decentralized sub-island without power supply module (maximum distance depends on current on conductors CS and ⊥)

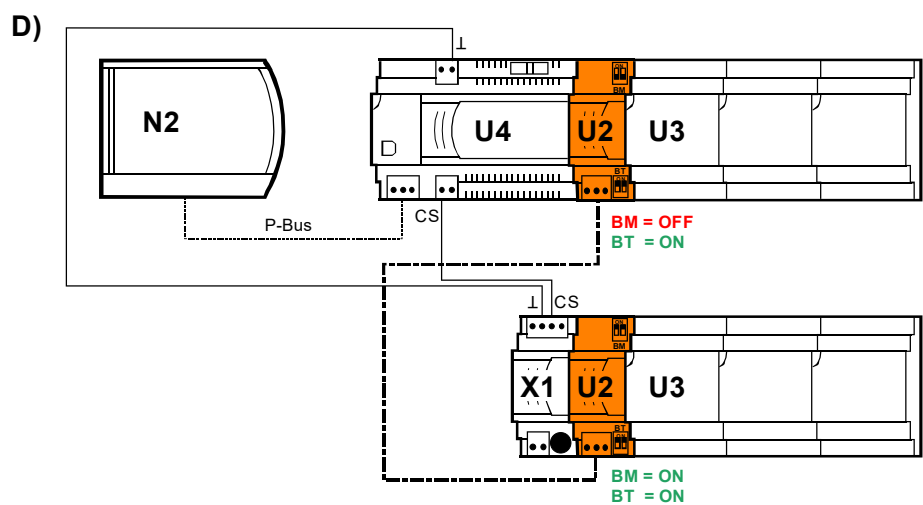

8184A11b



## Dimensions

Dimensions in mm

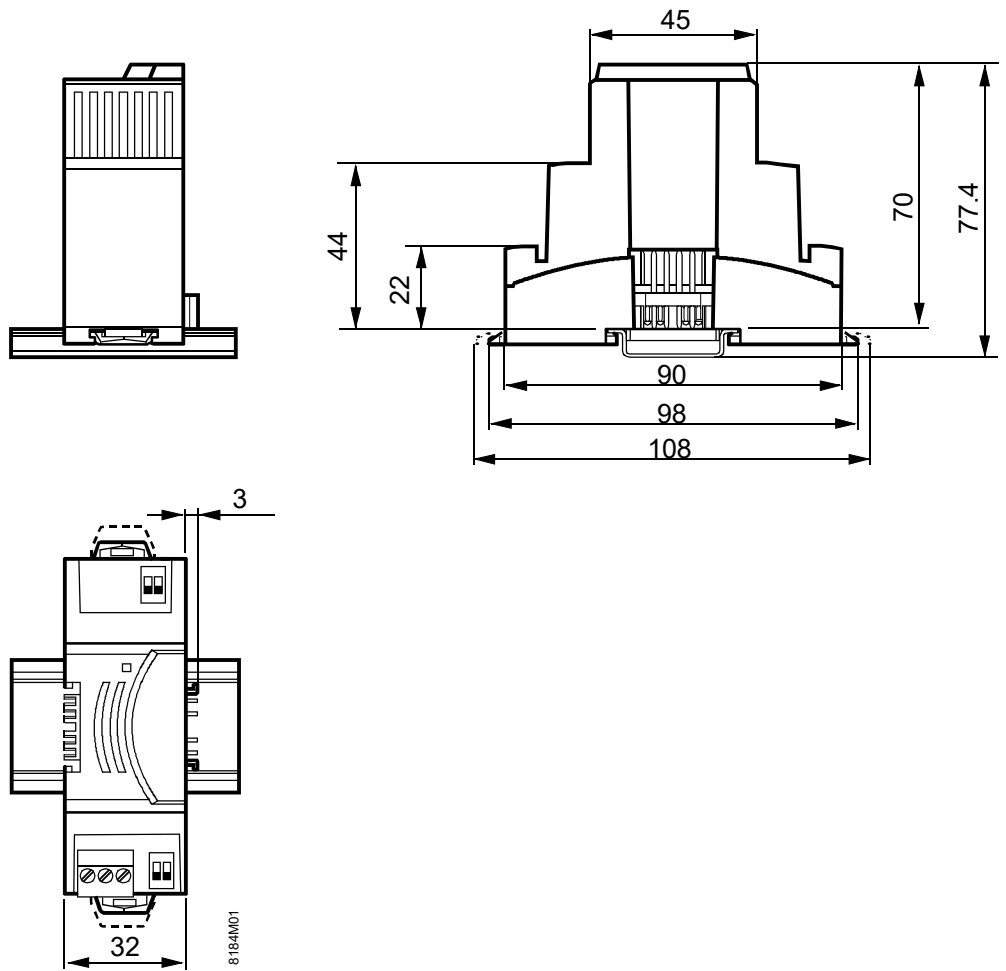

Issued by  
Siemens Switzerland Ltd  
Smart Infrastructure  
Global Headquarters  
Theilerstrasse 1a  
CH-6300 Zug  
Tel. +41 58 724 24 24

[www.siemens.com/buildingtechnologies](http://www.siemens.com/buildingtechnologies)

© Siemens Switzerland Ltd 2012  
Technical specifications and availability subject to change without notice