

**MOES**  
HOME SMART MOES HOME

works with **Tuya**

## Instructional Manual Smart Control Panel



English

WORKS WITH alexa

WORKS WITH Google Assistant

CCP-US-AVS-MS-DF21

Bitte scannen Sie den QR-Code, um das deutsche Handbuch, das Installationsvideo und die Funktionseinführung zu erhalten.

Escanee el código QR para obtener el manual en español, el video de instalación y la introducción de la función.

Veuillez scanner le code QR pour obtenir le manuel en français, la vidéo d'installation et l'introduction des fonctions.

Отсканируйте QR-код, чтобы получить руководство на русском языке, видео по установке и описание функций.

Scansionare il codice QR per ottenere il manuale in italiano, il video di installazione e la guida alle funzionalità. Video di installazione e funzionalità

Leia o código QR para obter o manual em português, o vídeo de instalação e a introdução das funções.

Zeskanuj kod QR, aby uzyskać instrukcje, filmy instalacyjne i funkcje.

QR 코드를 스캔하면 한국어 설명서, 설치 동영상, 기능 가이드를 볼 수 있습니다.

QRコードを読み取ると、日本語の説明書、インストールビデオ、機能ガイドが表示されます。

من الكود QR يمكنك الحصول على دليل المستخدم باللغة العربية وتعليمات التركيب والفيديو التعليمي.



### Product specifications

Product name	Smart Control Panel
Product model	CCP-US-AVS
Input	100~240V~, 50/60Hz, 5A MAX
Wireless protocol	Wi-Fi, Zigbee
Max load ratings	Tungsten/Incandescent 200W Dimmable CFL/LED 200W Ballast/Fluorescent 200VA
Working temperature	0°C~40°C
Working Humidity	5%~90%RH non-condensing
Product size	72x127.3x10.5mm (base excluded) 72x127.3x36.5mm (base included)
Net weight	215g

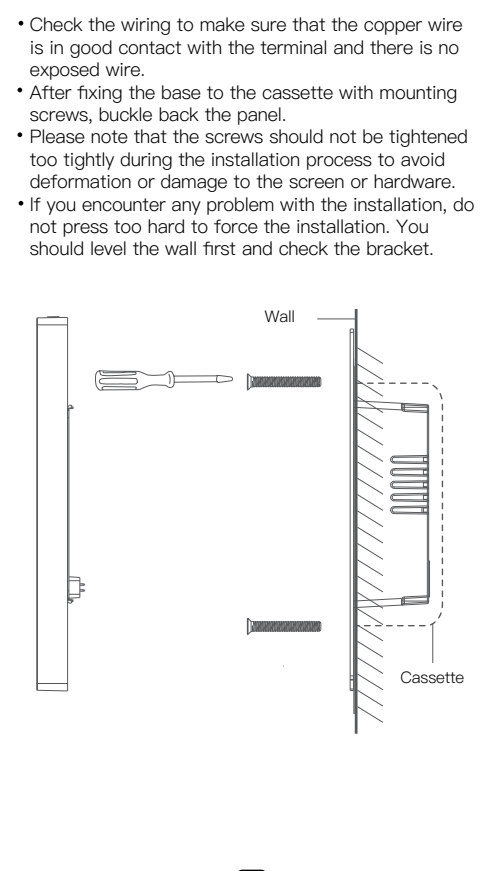
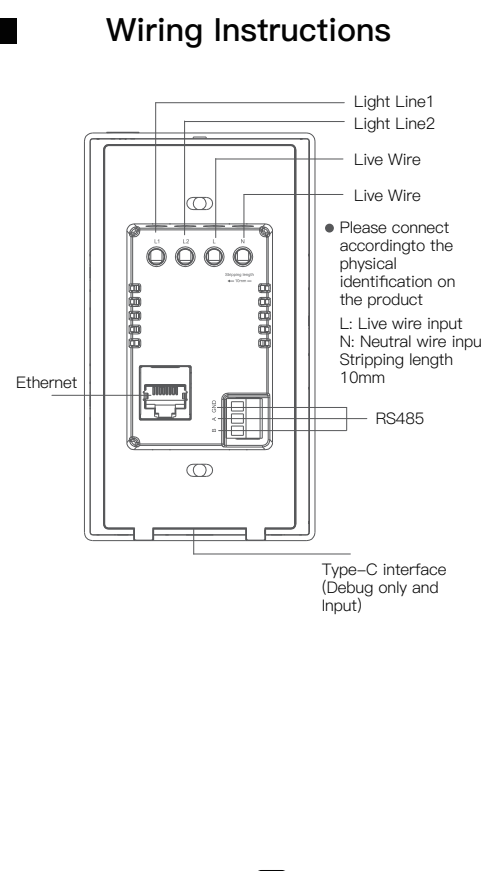
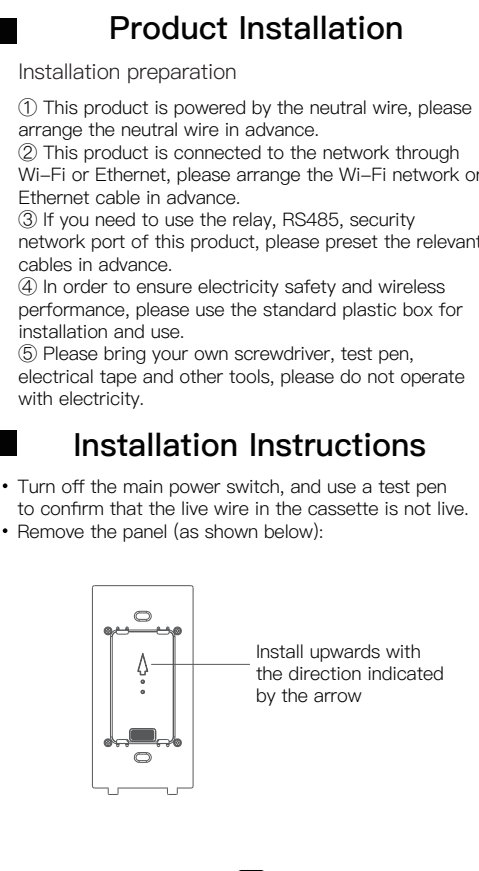
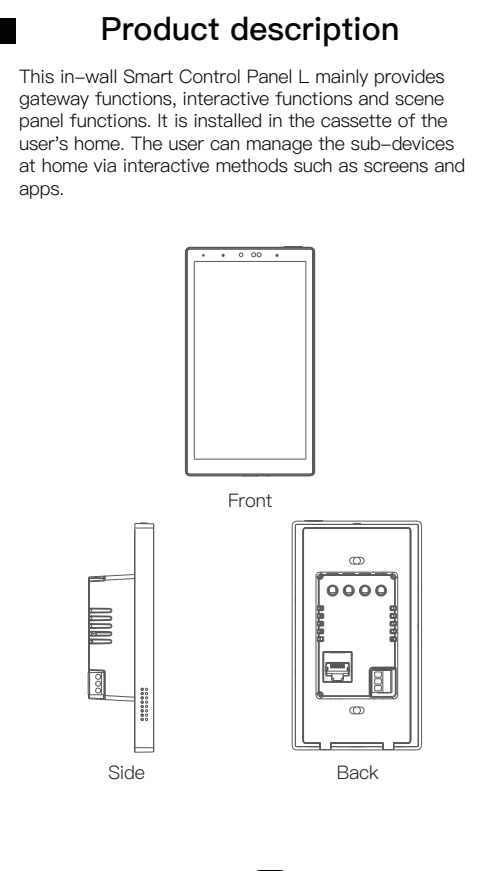

### Preparation for use

- Download MOES App on App store or scan the QR code.
- Registration or Log in.
  - Download "MOES" Application.
  - Enter the Register/Login interface, tap "Register" to create an account by entering your phone number to get verification code and "Set password". Choose "Log in" if you already have a MOES account.

MOES application is much more compatible than Tuya smart / smart life application. It also provides a new customized service for controlling scenes through Siri, widgets and scene recommendation. (Note: Tuya smart / Smart Life app is still working, but moes app is highly recommended)

### Commission settings

- Install the device according to the installation guide. Turn on the power, and wait for the device to initiate. Connect the network according to the instructions on the screen.
- Open the MOES App, then scan the QR code on the device to configure the network. (as shown in the figure below) and perform related operations according to the instructions on the device interface after the commission is successfully finished.

\*The QR code is based on the display of actual device

### Function introduction

**Device/Scene overview:** Smart Control Panel would automatically acquire the device and scene list of your app account, you could control them on the screen.

**Voice control:** please find the voice entry in the Smart Control Panel page of MOES App, and you could perform voice control after logging in.

**Gateway function:** enter the corresponding entrance in the Smart Control page of MOES App, and add Zigbee sub-devices.

**Setting:** slide down at the top of the device screen to call out the setting page.

### Notes

- In order to ensure the correct use of this product, it must be installed, maintained and disassembled by a professional electrician.
- Before installing and disassembling this product, the main power switch must be cut off to prevent electric shock.
- This product should be kept away from fire and water sources during installation and use, and should not be used in humid environments (such as bathrooms).
- Confirm that the voltage is in line with the working voltage of this product before use, and do not insert the PE network cable into the network port.
- Do not repair the product by yourself. Any modification or flashing of the product without authorization will void the warranty.
- The product needs to be installed by technicians. The installation environment is concrete wall.

### FCC Notice

This device complies with Part 15 of the FCC Rules. Operation is subject to the following two conditions: (1) this device may not cause harmful interference, and (2) this device must accept any interference received, including interference that may cause undesired operation.

The users manual or instruction manual for an intentional or unintentional radiator shall caution the user that changes or modifications not expressly approved by the party responsible for compliance could void the user's authority to operate the equipment. In cases where the manual is provided only in a form other than paper, such as on a computer disk or over the Internet, the information required by this section may be included in the manual in that alternative form, provided the user can reasonably be expected to have the capability to access information in that form.

(b) For a Class B digital device or peripheral, the instructions furnished the user shall include the following or similar statement, placed in a prominent location in the text of the manual:

NOTE: This equipment has been tested and found to comply with the limits for a Class B digital device, pursuant to Part 15 of the FCC Rules. These limits are designed to provide reasonable protection against harmful interference in a residential installation. This equipment generates, uses and can radiate radio frequency energy and, if not installed and used in accordance with the instructions, may cause harmful interference to radio communications.

### RF exposure warning

This equipment must be installed and operated in accordance with provided instructions and the antenna(s) used for this transmitter must be installed to provide a separation distance of at least 20 cm from all persons and must not be co-located or operating in conjunction with any other antenna or transmitter. End-users and installers must be provided with antenna installation instructions and transmitter operating conditions for satisfying RF exposure compliance.

### Non-warranty regulations

- Unauthorised maintenance, misuse, collision, negligence, abuse, liquid ingress, accident, alteration, incorrect use of non-original accessories, or tearing off/altering of labels or anti-counterfeit marks.
- Expiration of validity period of the warranty services of repair, replacement and refund.
- Damage caused by force majeure.
- Other damages or malfunctions that are not caused by the product's own design, technology, manufacturing, quality and other issues.

### Control your home with your voice

Devices are compatible with Amazon Alexa and Google Home supported functionalities.

Please see our step-by-step guide on: <https://www.moestech.com/blogs/news/smart-voice-linked-voice-speaker>

### WARRANTY INSTRUCTIONS

Dear Sir or Madam, thank you for purchasing the product. We hope you'll enjoy using it.

The warranty for the products in the warranty card is hereby granted as follows:

As a condition of using the warranty, you must comply with the following terms and procedures:

- Products are covered by a 24-month warranty, effective from the date of purchase of the covered product by a retail customer.
- In order to exercise warranty rights, the purchaser must present: a) Warranty card, b) Proof of purchase (VAT invoice, financial receipt or other document confirming the actual date of purchase), unless the purchase date of the product comes from the warranty card.
- If product quality problems occur within 24 months from the date of receipt, please prepare the product and packaging and go to the place or store where you purchased it to apply for after-sales maintenance. If the product is damaged due to personal reasons, a certain maintenance fee will be charged.
- We recommend that you properly protect the goods when delivering them to the guarantor - for this purpose, we recommend that you use the original packaging with padding to ensure safe transportation. If you choose to use replacement packaging, we recommend that you ensure that the product is adequately protected from damage during shipping. We recommend that you place an appropriate sticker on your packaging indicating the product's susceptibility to impact, such as "Warning Glass".
- Reported defects covered by the warranty will be considered immediately and no later than 14 days from the date of delivery of the goods to the Guarantor.
- After checking and determining the legality of the user manual, and users are obliged to do it themselves.
- If defects occur due to natural wear and tear during use, the warranty does not cover it.
- The warranty does not cover:
  - Mechanical damage caused by the user's fault and product defects caused by such damage.
  - Damage caused by improper use of the product.
  - Remove the warranty seal from the product.
  - Remove the serial number from the product.
  - Take action to eliminate physical defects in the product outside of authorized services.
  - Use non-original parts and consumables.

### WARRANTY CARD

Product Information

Product Name: \_\_\_\_\_  
 Product Type: \_\_\_\_\_  
 Purchase Date: \_\_\_\_\_  
 Warranty Period: \_\_\_\_\_  
 Dealer Information: \_\_\_\_\_  
 Customer's Name: \_\_\_\_\_  
 Customer Phone: \_\_\_\_\_  
 Customer Address: \_\_\_\_\_

Maintenance Records

Failure date	Cause Of Issue	Fault Content	Principal

Thank you for your support and purchase at we Moes, we are always here for your complete satisfaction, just feel free to share your great shopping experience with us.

★★★★★

If you have any other need, please do not hesitate to contact us first, we will try to meet your demand.

**FOLLOW US**

@moes\_smart  
 @moes\_smart  
 @moesmart

MOES Official  
 www.moestech.com  
 @moes\_smart

E-CrossStu-GmbH  
 Mainzer Landstr. 69, 60329 Frankfurt am Main  
 Email: E-crossstude@de  
 Tel: +496932987674  
 Made in China

EVATOST CONSULTING LTD  
 Address: Suite 11, First Floor, Moy Road  
 Business Centre, Taffs Well, Cardiff,  
 Wales, CF15 7GP  
 Tel: +442921680945  
 Email: contact@evatmaster.com

Manufacturer:  
 WENZHO NOVA NEW ENERGY CO.,LTD  
 Address: Power Science and Technology Innovation Center, NO.238, Wei 11 Road, Yueqing Economic Development Zone, Yueqing, Zhejiang, China  
 Tel: +86-577-87198615  
 After-sale Service: service@moestech.com

**MOES**  
HOME SMART MOES HOME

works with **Tuya**

## Manual de instrucciones Panel de control inteligente



Español

WORKS WITH alexa

WORKS WITH Google Assistant

CCP-US-AVS-MS-DF21

### Especificaciones del producto

Nombre del producto	Panel de control inteligente
Modelo del Producto	CCP-US-AVS
Aporte	100~240V~, 50/60Hz, 5A MAX
Protocolo inalámbrico	Wi-Fi, Zigbee
Clasificaciones de carga máxima	Tungsten/Incandescent 200W Regulable CFL/LED 200W Ballast/Fluorescente 200VA
Temperatura de trabajo	0°C~40°C
Humedad de trabajo	5%~90%RH sin condensación
Tamaño del producto	72x127.3x10.5mm (base excluida) 72x127.3x36.5mm (base incluida)
Peso neto	215g

### Descripción del Producto

Este panel de control inteligente L de pared proporciona principalmente funciones de puerta de enlace, funciones interactivas y funciones de panel de escena. Se instala en el casete del domicilio del usuario. El usuario puede gestionar los subdispositivos en casa mediante métodos interactivos, como pantallas y aplicaciones.

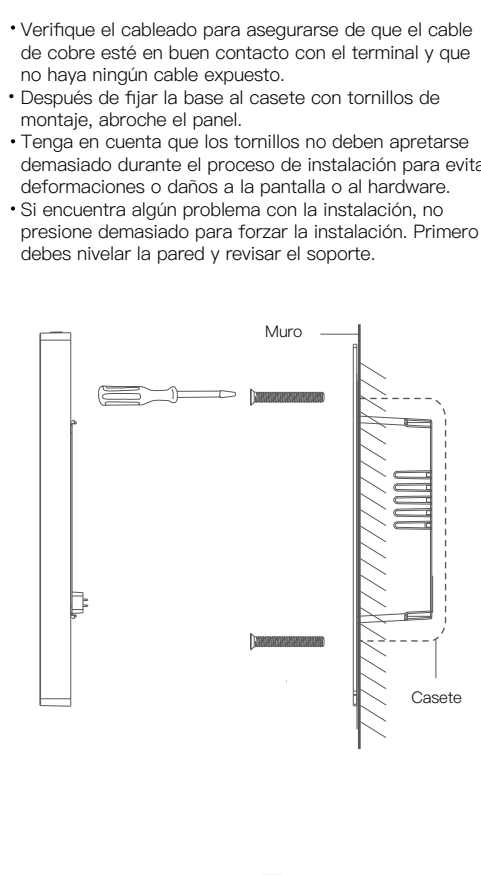
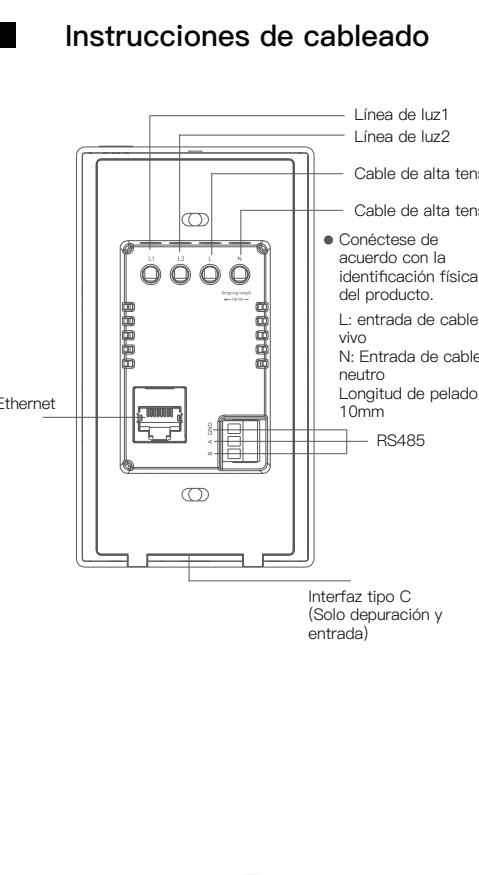
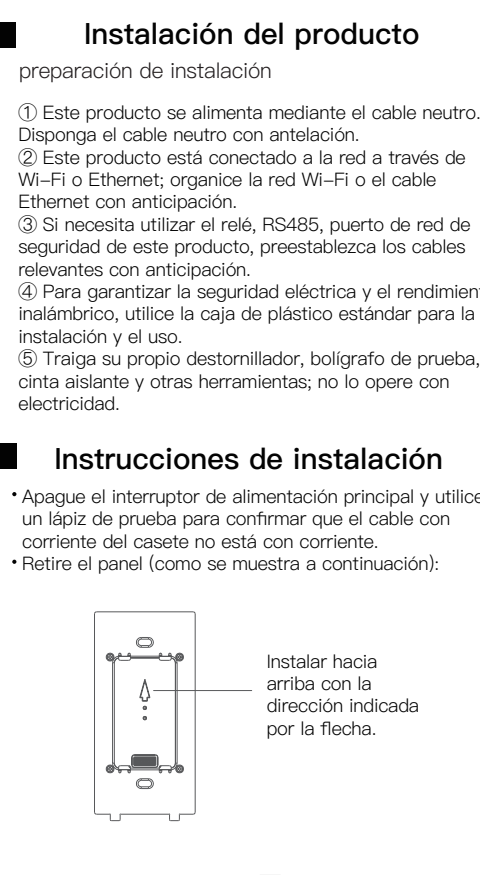

### Preparación para su uso

- Descargue la aplicación MOES en la tienda de aplicaciones o escanee el código QR.
- Regístrate o inicia sesión.
  - Descargue la aplicación "MOES".
  - Ingrese a la interfaz Registrarse/Iniciar sesión; toque "Registrarse" para crear una cuenta ingresando su número de teléfono para obtener el código de verificación y "Establecer contraseña". Elija "Iniciar sesión" si ya tiene una cuenta MOES.

La aplicación Moes es mucho más compatible que la aplicación Tuya smart / smart life. También proporciona un nuevo servicio personalizado para controlar escenas a través de Siri, widgets y recomendación de personas. (Nota: la aplicación Tuya smart / Smart Life todavía funciona, pero se recomienda encarecidamente la aplicación moes)

### Instrucciones de garantía

Estimado Señor o señora, gracias por comprar el producto. Esperamos que le guste usarlo.

Se otorga la siguiente garantía a los productos en la tarjeta de garantía. Como condición para el uso de la garantía, debe cumplir con los siguientes términos y procedimientos:

- el producto goza de una garantía de 24 meses, que entrará en vigor a partir de la fecha en que el cliente minorista compra el producto cubierto.
- para ejercer la garantía, el comprador debe presentar: a) la tarjeta de garantía, b) el certificado de compra (factura de IVA, recibo financiero u otro documento que confirme la fecha real de compra), a menos que la fecha de compra del producto provenga de la tarjeta de garantía.
- dentro de los 24 meses siguientes a la fecha de recepción del producto, si hay problemas de calidad del producto, prepare el producto y el embalaje y vaya al lugar de compra o tienda para solicitar el mantenimiento post-venta. Si el producto se daña por razones personales, se cobrará una cierta tarifa de mantenimiento.
- la garantía no incluye:
  - los daños mecánicos causados por la negligencia del usuario y los defectos resultantes del producto.
  - daños causados por el uso inadecuado del producto.

### Introducción a la función

**Descripción general del dispositivo/escena:** el Panel de control inteligente adquirirá automáticamente la lista de dispositivos y escenas de su cuenta de aplicación, podrá controlarlos en la pantalla.

**Control por voz:** toque la entrada de voz en la página del Panel de control inteligente de la aplicación MOES y podrá realizar el control por voz después de iniciar sesión.

**Función de puerta de enlace:** ingrese la entrada correspondiente en la página Smart Control de la aplicación MOES y agregue subdispositivos Zigbee.

**Configuración:** deslice hacia abajo en la parte superior de la pantalla del dispositivo para acceder a la página de configuración.

**MOES**  
HOME SMART MOES HOME

works with **Tuya**

## Manual de instruções Panel de controle inteligente



Português

WORKS WITH alexa

WORKS WITH Google Assistant

CCP-US-AVS-MS-DF21

### Especificações do produto

Nome do Produto	Panel de controle inteligente
Modelo do produto	CCP-US-AVS
Entrada	100~240V~, 50/60Hz, 5A MAX
Protocolo sem fio	Wi-Fi, Zigbee
Classificações de carga máxima	Tungsten/Incandescent 200W Regulable CFL/LED 200W Ballast/Fluorescente 200VA
Temperatura de trabalho	0°C~40°C
Umidade de trabalho	5%~90%RH Sem Condensação
Unidade de trabalho	72x127.3x10.5mm (base excluída) 72x127.3x36.5mm (base incluída)
Tamanho do produto	72x127.3x10.5mm (base excluída) 72x127.3x36.5mm (base incluída)
Peso líquido	215g

### Descrição do produto

Este painel de controle inteligente L embutido na parede fornece principalmente funções de gateway, funções interativas e funções de painel de cena. É instalado no casete da residência do usuário. O usuário pode gerenciar os subdispositivos em casa por meio de métodos interativos, como telas e aplicativos.

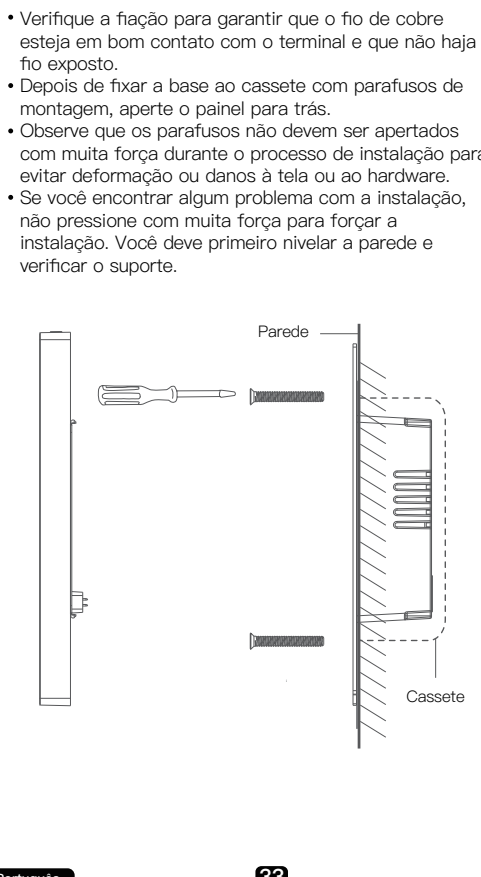
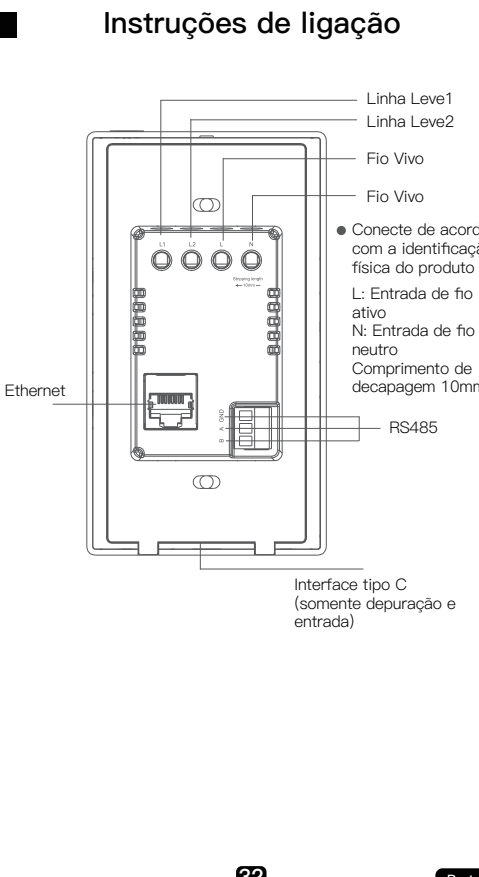
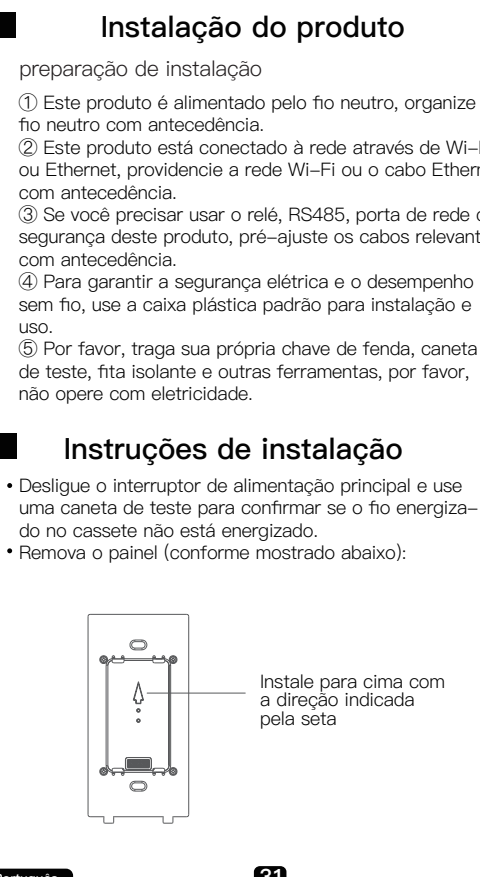

### Preparação para uso

- Baixar o aplicativo MOES na App Store ou escanear o código QR.
- Cadastre-se ou faça login.
  - Baixar aplicativo "MOES".
  - Entre na interface Cadastro/Login; toque em "Registrar" para criar uma conta digitando seu número de telefone para obter o código de verificação e "Definir senha". Escolha "Login" se você já possui uma conta MOES.

O aplicativo Moes é muito mais compatível do que o aplicativo Tuya smart / smart life. Também oferece um novo serviço personalizado para controle de cenas por meio de Siri, widgets e recomendação de cenas. (Observação: o aplicativo Tuya smart / Smart Life ainda está funcionando, mas o aplicativo moes é altamente recomendado)

### Instruções de garantia

Caro senhor ou senhora, obrigado por comprar o produto. Esperamos que você goste de usá-lo.

A garantia para os produtos no cartão de garantia é concedida da seguinte forma. Como condição para usar a garantia, você deve cumprir os seguintes termos e procedimentos:

- Os produtos são cobertos por uma garantia de 24 meses, efetiva a partir da data de compra do produto coberto por um cliente varejista.
- Para exercer os direitos de garantia, o comprador deve apresentar: a) cartão de garantia, b) comprovante de compra (fatura IVA, recibo financeiro ou outro documento confirmando a data real da compra), a menos que a data de compra do produto venha do cartão de garantia.
- Se problemas de qualidade do produto ocorrerem dentro de 24 meses a partir da data de recebimento, prepare o produto e o embalagem e vá para o lugar ou loja onde você comprou para aplicar para manutenção pós-venda. Se o produto for danificado devido a razões pessoais, uma certa taxa de manutenção será cobrada.
- A garantia não cobre:
  - Danos mecânicos causados pela falha do usuário e defeitos do produto causados por tais danos.
  - Danos causados pelo uso indevido do produto.

### Introdução à função

**Visão geral do dispositivo/cena:** o painel de controle inteligente adquirirá automaticamente a lista de dispositivos e cenas da sua conta de aplicativo, você poderá controlá-los na tela.

**Controle de voz:** encontre a entrada de voz na página do painel de controle inteligente do aplicativo MOES e você poderá executar o controle de voz após fazer login.

**Função de gateway:** insira a entrada correspondente na página Smart Control do aplicativo MOES e adicione subdispositivos Zigbee.

**Configuração:** deslize para baixo na parte superior da tela do dispositivo para acessar a página de configuração.